

GE2318

FROM ANCIENT WISDOM
TO MODERN SCIENCE

古代智慧與現代科學

執古之道，以禦之有。 —— 老子

意譯：

把握自古存在的道理，以便駕御當今發生的事物。



Networks



Chaos

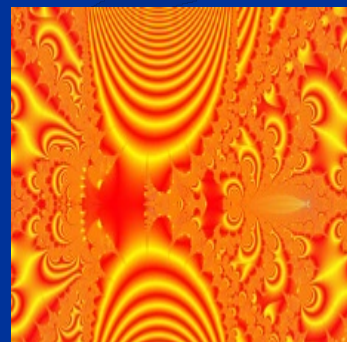

Fractals



AI

Course Contents

- Part I
 Networks
- Part II
 Chaos
- Part III
 Fractals
- Part IV
 AI

Part I Networks (網絡)

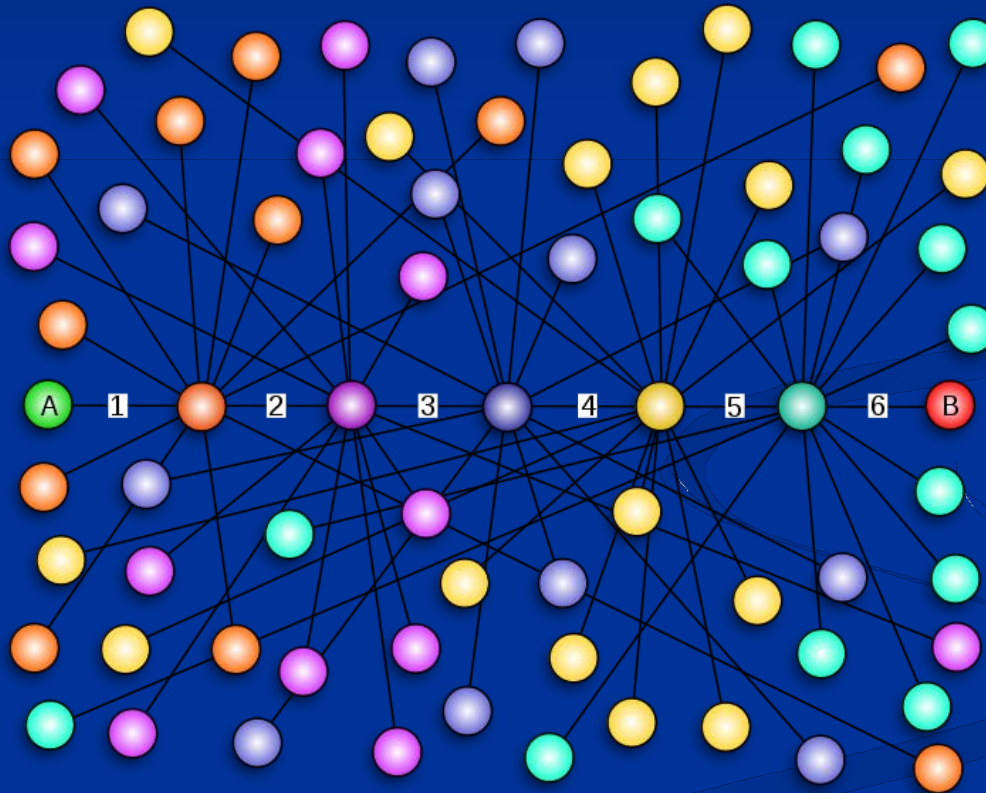

Part I Networks (網絡)

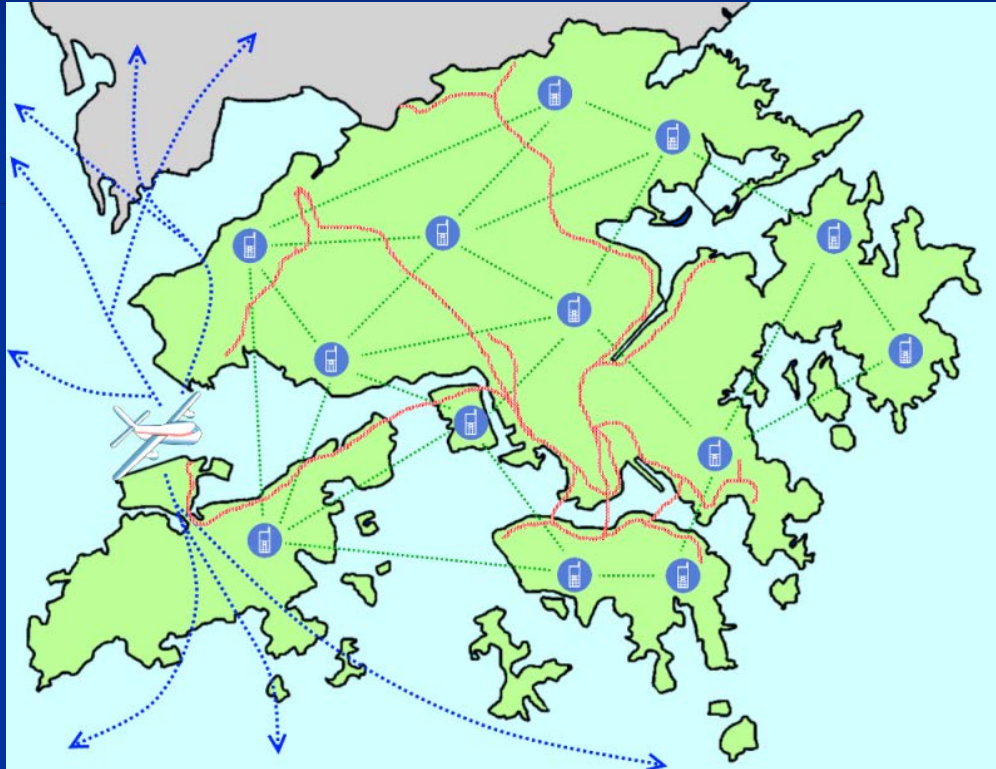

Wallace K S Tang

Acknowledgement: Un-copyrighted photos and pictures were taken from the Internet

Facebook



December 2010

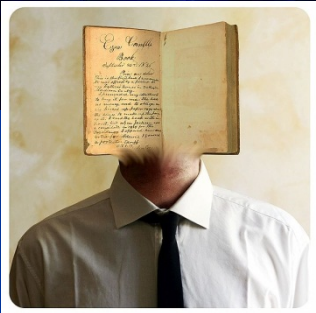

www.bbc.co.uk (24 Dec 2010)

Airlines Route Maps

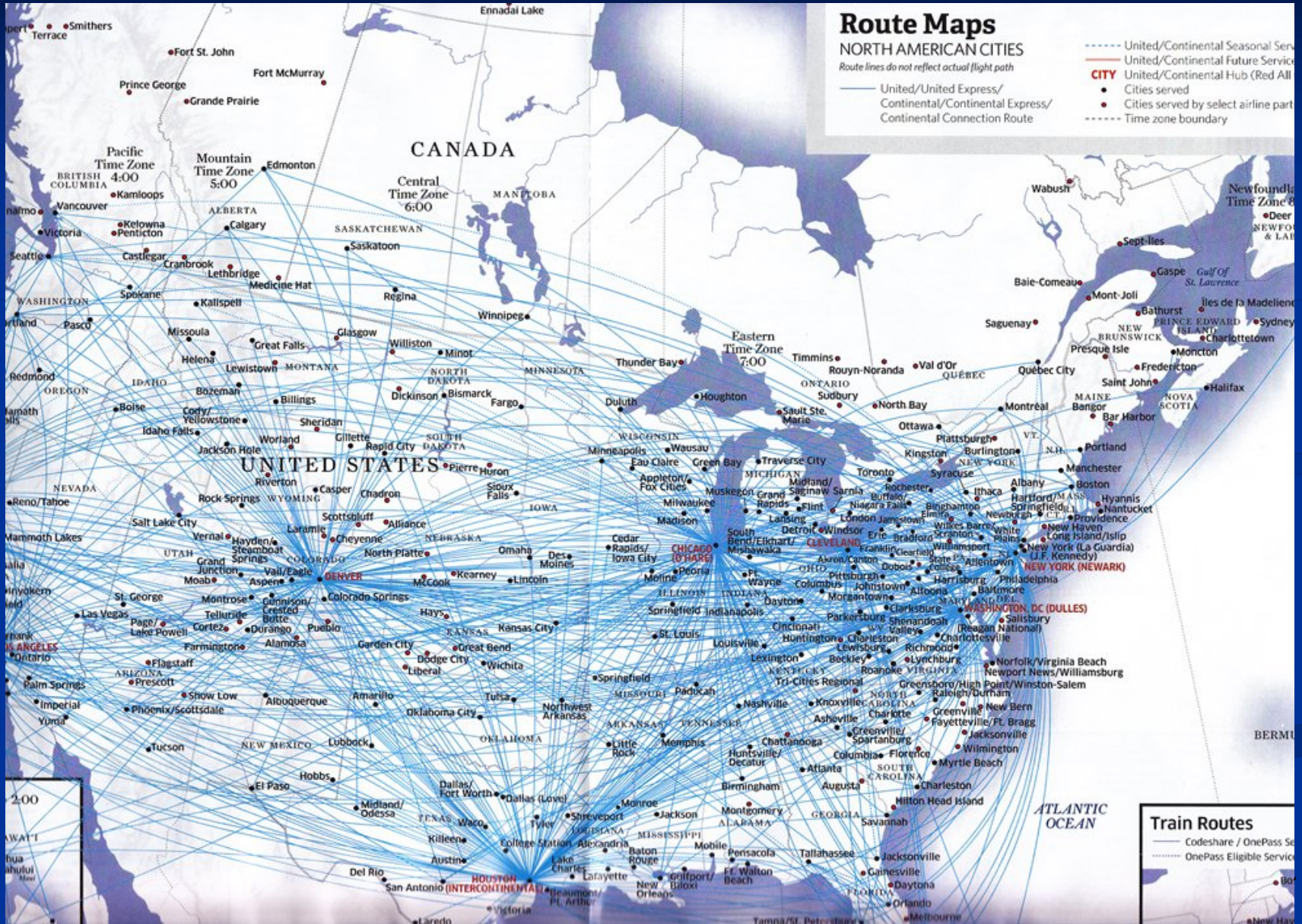

Railway and Subway Road Maps

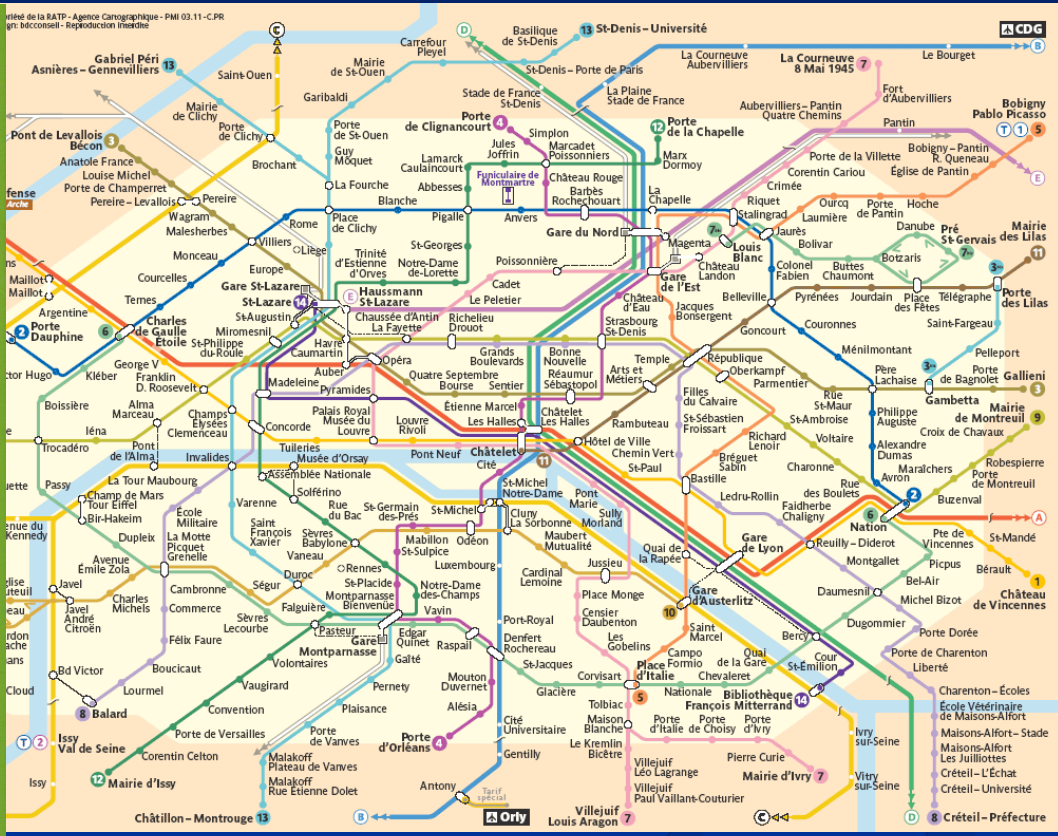

Tokyo Subways

Computer Networks

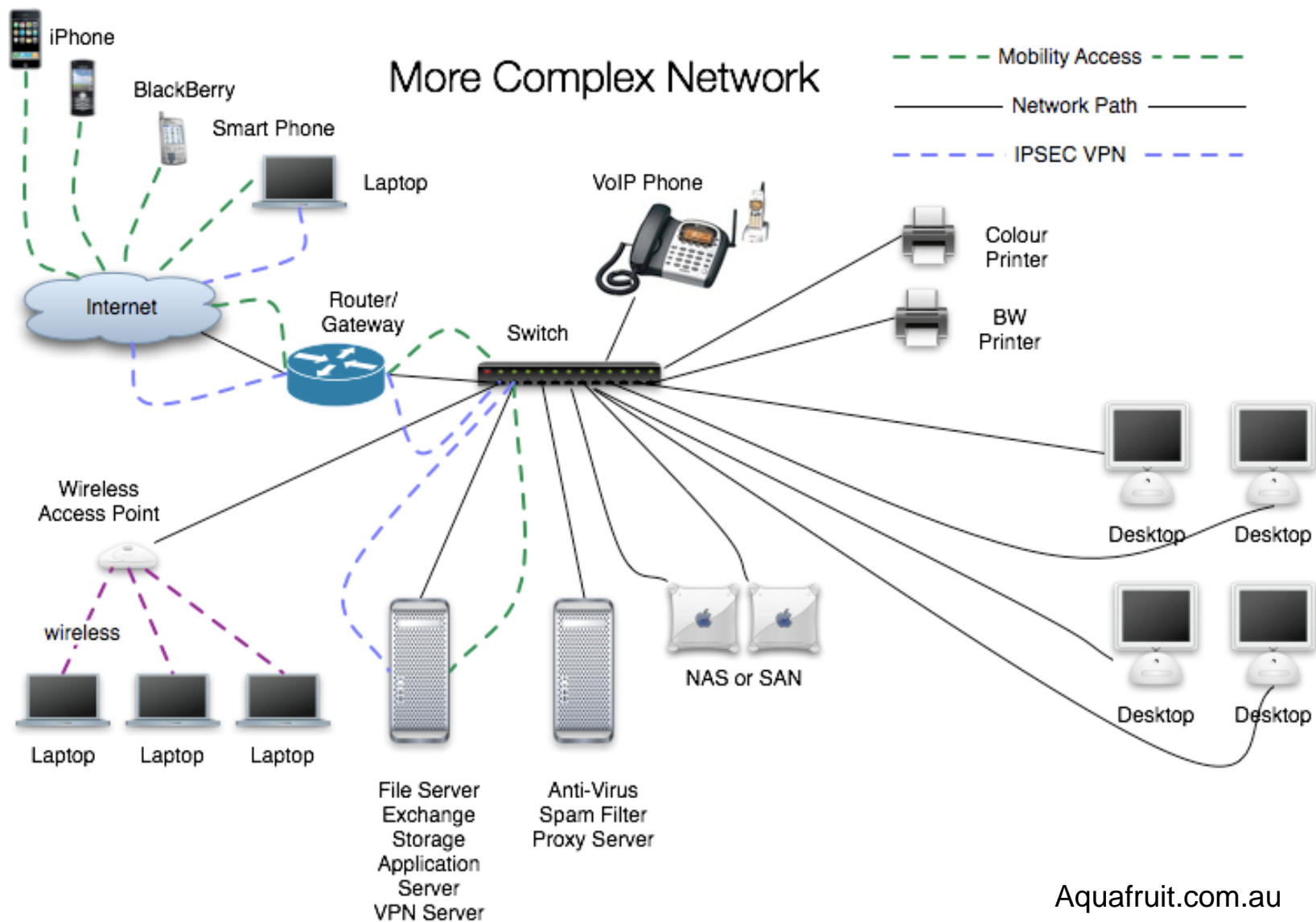

VLSI Integrated Circuits

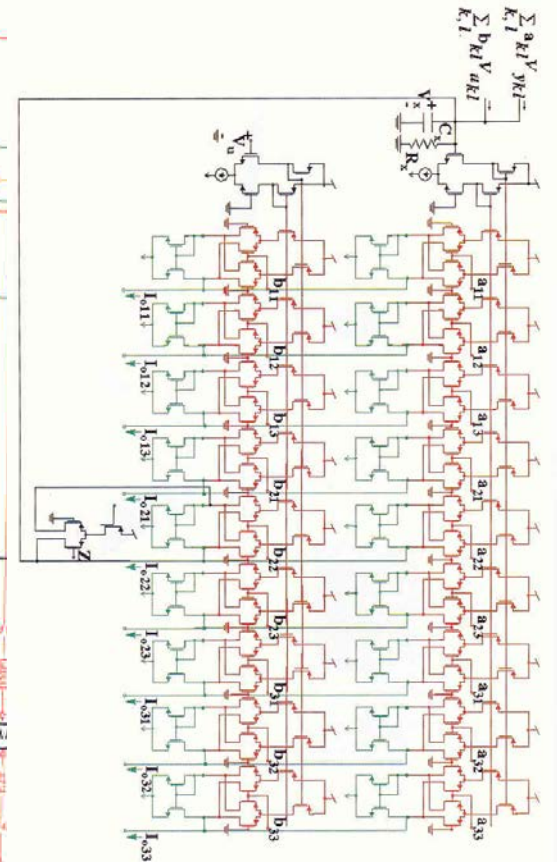
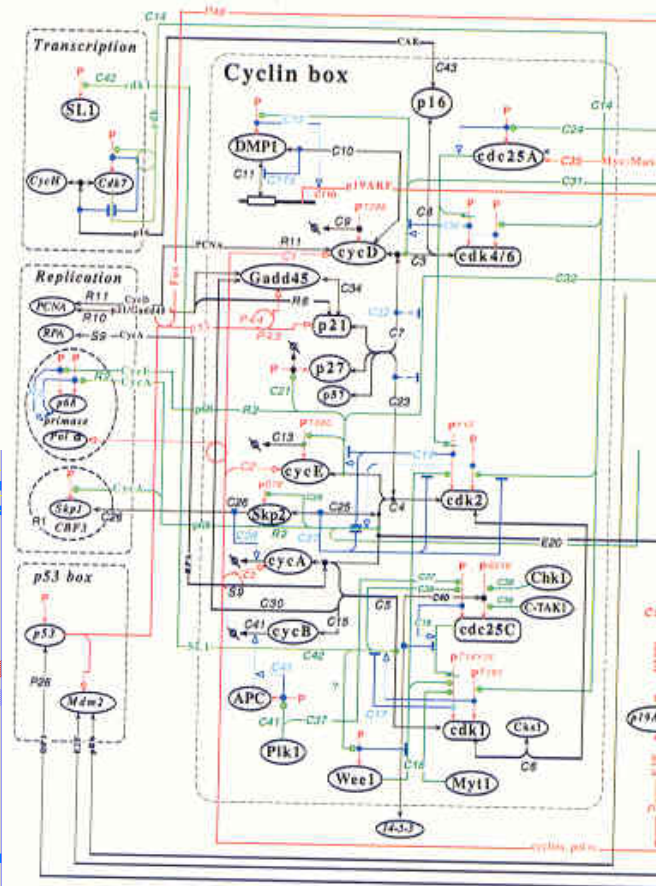
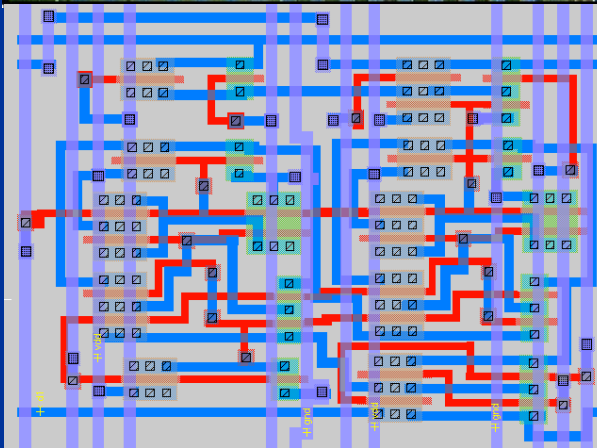
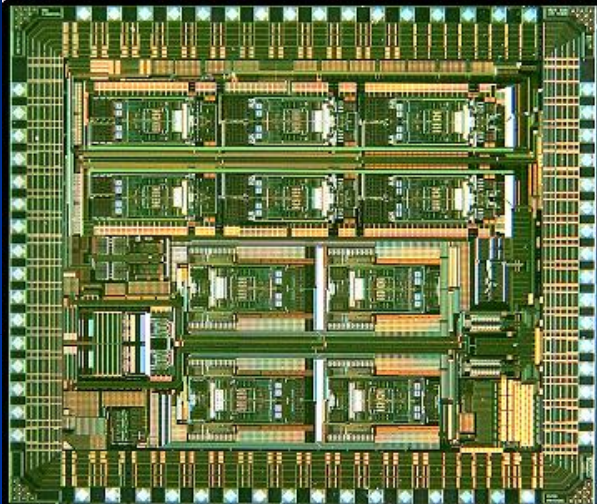

Biological Networks

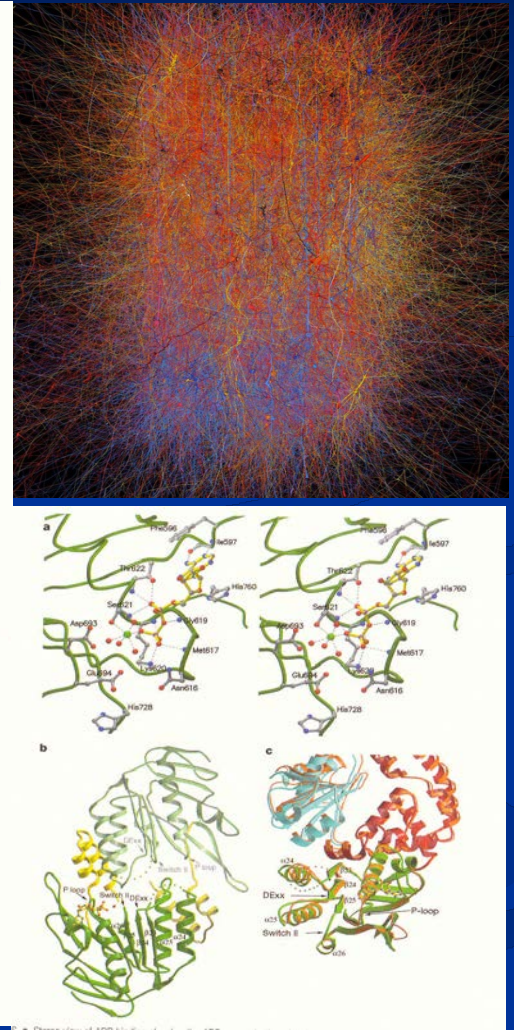
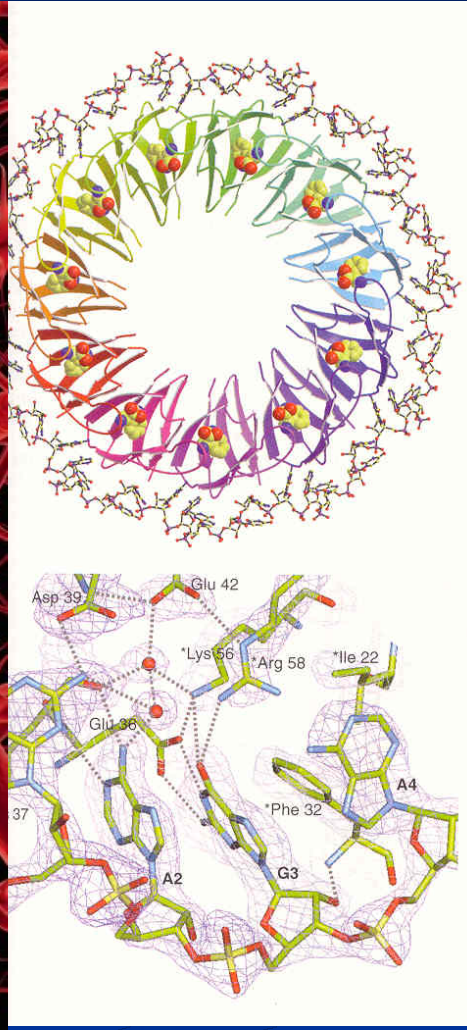
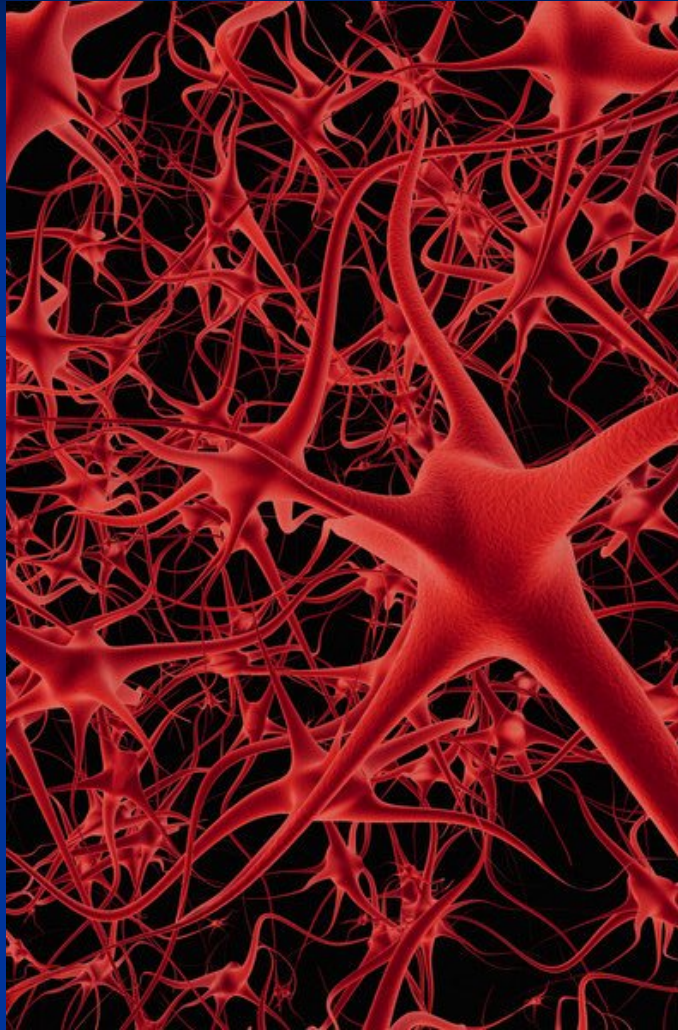

Social Networks



Above All --- Internet of Things

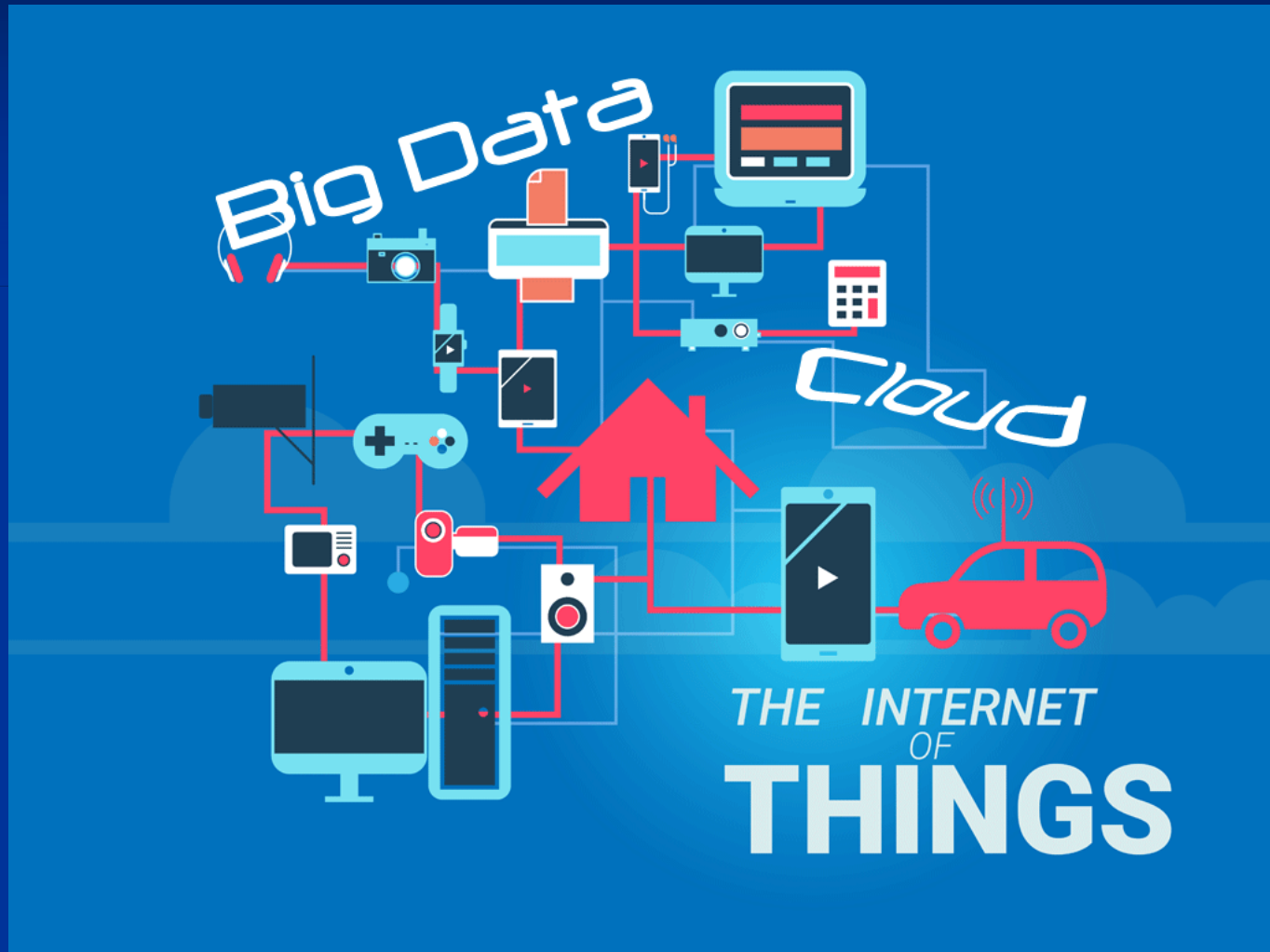

This part covers

Graph Theory and Complex Networks

- Basic Graph Theory
- Some stories about Complex Networks
- How to generate Complex Networks
- Characteristics of Complex Networks
- Applications of Complex Networks

Part II Chaos (混沌)



CHAOS



Political turmoil?

Disorderly life?

Natural disaster?



Chaos has much more to tell

Literature

Philosophy

Religion

...

Science

Engineering

唐詩

《全唐詩》卷377

泛黃河

孟郊

誰開昆侖源，流出混沌河。
積雨飛作風，驚龍噴為波。
湘瑟颼颼弦，越竇嗚咽歌。
有恨不可洗，虛此來經過。



黃河壺口

《聖經》 Bible

Bible – **chaos** is the disordered state of the world before the intervention of God.

“Now the earth was formless and empty,” Genesis 1:2

「地是空虛**混沌**...」創世記 1章2節

Chaos is a concept related to the state of complete emptiness or destruction



CHAOS 在希臘神話中

the Theogony begins by explaining the genealogy of the gods (figure 11.2). It relates that in the beginning there arose **Chaos**, a formless mass of infinite extent.* Out of **Chaos**, in turn, came the first five deities: **Gaea** (Earth), Tartarus (a dark pit in the depths of hell), Eros (Love), Nix (Night), and Erebus (the darkness of Tartarus).

在希臘神話中，一切皆從 **混沌 (chaos)** 開始

宇宙之初，只有**混沌 (chaos)**，它是一個無邊無際、一無所有的空間。隨後誕生了地母神蓋亞 (Gaea)、地獄深淵神塔耳塔洛斯 (Tartarus)、黑暗神俄瑞波斯 (Erebus)、黑夜女神尼克斯 (Nyx) 和愛神厄洛斯 (Eros)..... 世界從此開始。

中國古代關於混沌的故事

古人想像，天地未開闢以前，宇宙是模糊一團的狀態，稱為“混沌”。

《太上老君八十一化圖》之第二化：
“... 空洞之中，又生太無，太無之內生玄元始三氣，三氣相合，稱為混沌”

太上老君，為道教之主：出乎太無之先，起乎無極之源，經歷天地，不可稱載，終乎無終，窮乎無窮者也。[亦有一說，他是由老子演變而來]。

西元165年，邊韶作《老子銘》，說：“世之好道者觸類而長之，以老子離合於混沌之氣，與三光為終始。”故此，道教的經書《老子想爾注》中說：“一散形為氣，聚形為太上老君”。

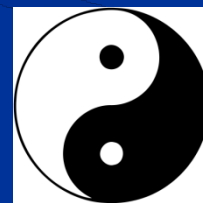

CHAOS in Modern Science

A new branch of science

Applications in many disciplines:

physics, engineering, social sciences, ...

THE SHAW PRIZE LECTURE

Organised by
THE UNIVERSITY OF HONG KONG





THE SHAW PRIZE
劉兆佳獎

Three Easy Pieces:
Examples of **Chaos**
in the **Solar System**

Professor *Peter Goldreich*
Winner of The Shaw Prize in Astronomy 2007

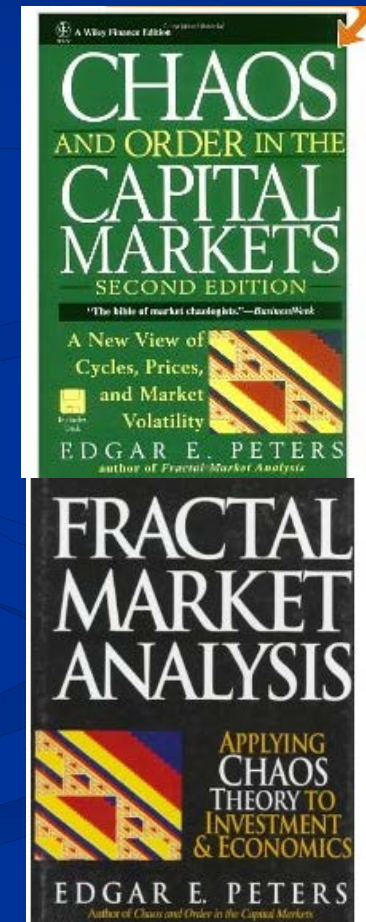
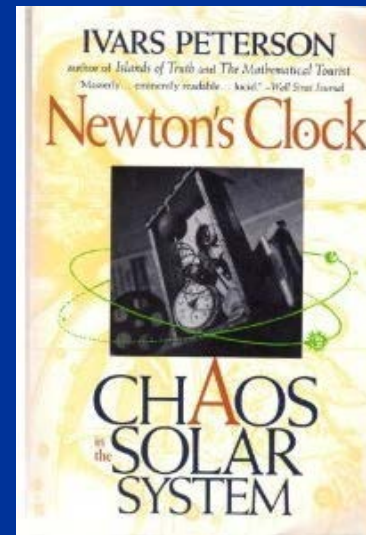
Date : September 12, 2007 (Wednesday)
Time : 11 am (Light refreshment will start at 10:30am)
Venue : Wang Gungwu Lecture Hall, Graduate House,
The University of Hong Kong



This part covers

All about **Chaos**

- Some stories about Chaos
- How to generate Chaos
- Characteristics of Chaos
- Applications of Chaos

Part III Fractals (分形)



Fractals

Fractal – Latin adjective “fractus”, meaning “to break”, creating irregular fragments

Fractal – A never ending pattern that repeats itself at different scales

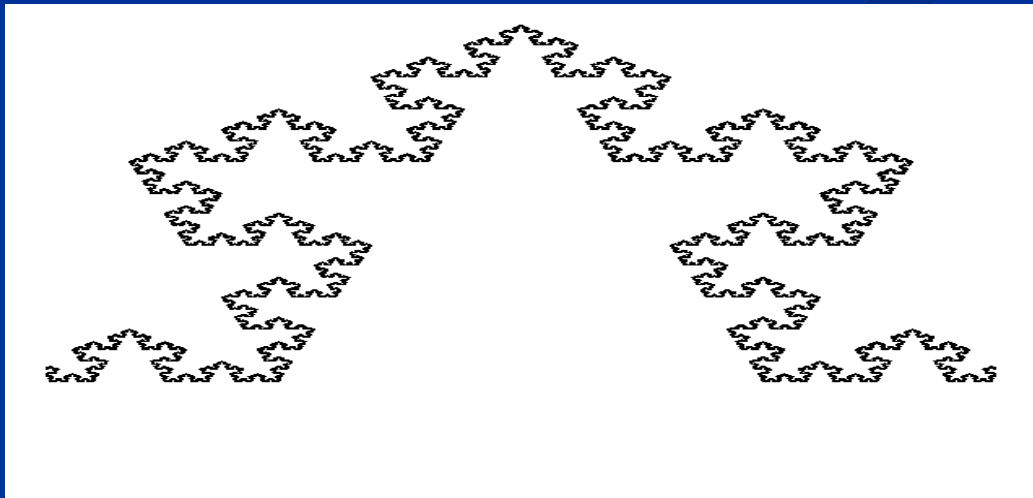

**Self
Similarities**

一葉一世界

梵網經 (Brahmajāla-sūtra)

其台周遍有千葉，一葉一世界，為千世界。我化為千釋迦據千世界，後就一葉世界，復有百億須彌山、百億日月、百億四天下、百億南閻浮提。百億菩薩釋迦，坐百億菩提樹下，各說汝所問菩提薩埵心地。其餘九百九十九釋迦，各各現千百億釋迦，亦復如是。

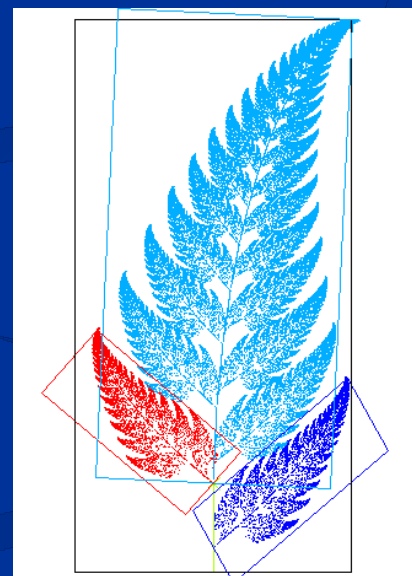
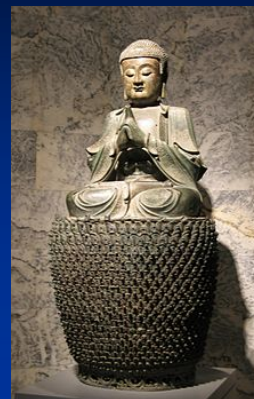

Self-Similarity in Nature



Romanesco Broccoli



Fern



Flashing



Sea Shell



Starfish

Self-Similarity in Architecture

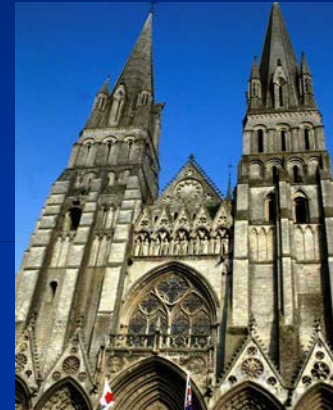
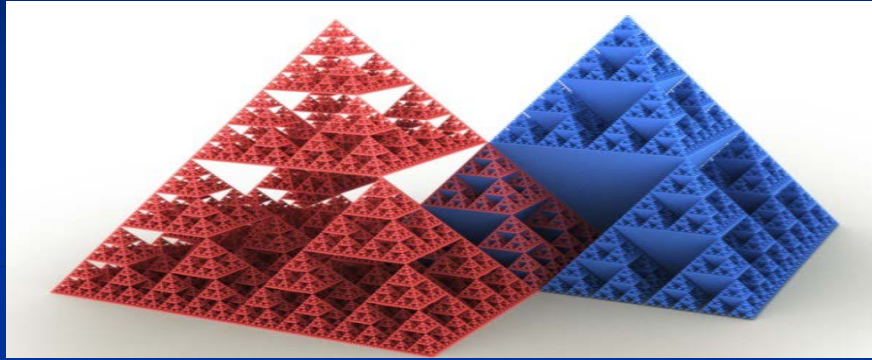

European Cathedrals



Mosaics in Church



Self-Similarity in Artworks and Fashion

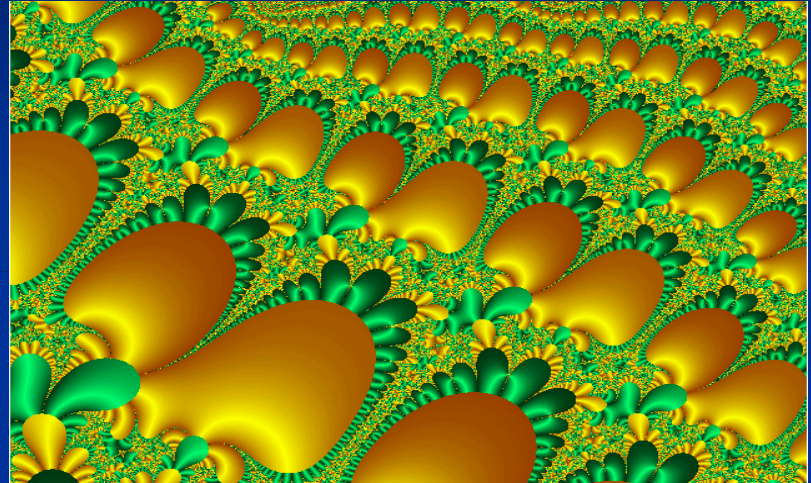
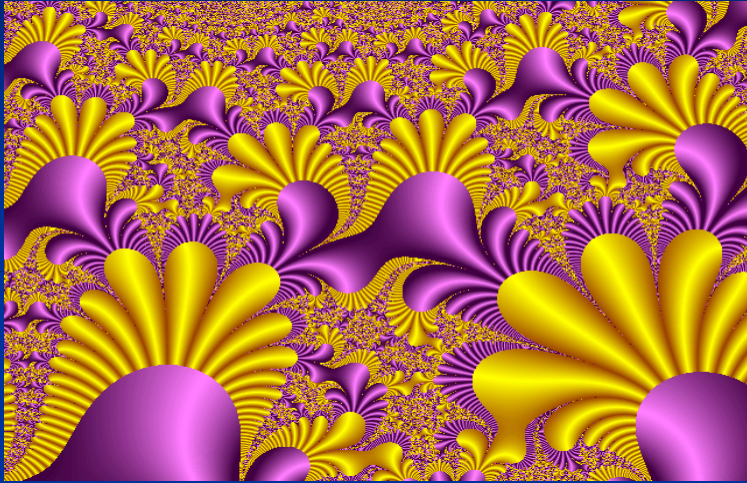

This part covers

All about **Fractals**

- Some stories about Fractals
- How to generate Fractals
- Characteristics of Fractals
- Applications of Fractals

Part IV AI (人工智能)



Artificial Intelligence is an interdisciplinary subject, interconnecting natural science and social science

It involves philosophy, cognition science, mathematics , neurophysiology, psychology, computer science, information theory, control systems, communications



AI has broad **applications** to:

- Robotics
- Computer vision
- Pattern recognition
- Expert systems
- Machine learning
- Automatic programming
- Neuromorphic computing
- Intelligent search
- Language simulation
- Graph perception
- Genetic algorithms
- Network games
- ...



This part covers

Big-Data

Artificial Neural Networks

Machine Learning / Deep Learning



GE2318

Course Requirements



Un-copyrighted photo from web

Teaching and Learning

- Lectures
- In-class Activities
- After-class Activities
- Reading and Self-learning

Assessments

- HW
- Reflective Essay Writing
- Reading Reports
- Final Exam

CityU Guidelines

Course Intended Learning Outcomes (CILO)

1. Describe the major concepts in some selected modern scientific topics, such as network science and complexity in modern science and technology
2. Describe the major concepts of some selected knowledge and wisdom on nonlinear science, such as chaos and fractals
3. Identify the relationship between fundamental knowledge and modern sciences
4. Understand daily-life complex phenomena from scientific perspectives

Course Requirements and Grading

In-class Exercises	20%
HW + After-class Reports	20%
Final Exam (duration: 2 hrs)	60%

CityU Guidelines for a student to pass the course:

Course Work > 30%

Examination > 30%

Lecturer



Contact information:

Prof G Ron Chen 陳關榮

- AC-1 G6306 (3442-7922)
- eegchen@cityu.edu.hk
- <http://www.ee.cityu.edu.hk/~gchen/>